

LIGHTWEIGHT ALUMINIUM STEP

Very light to move them easily

Completely welded.

REGULATIONS EN 14.183

- ✓ Approximate maximum working height (mts): 4.3
- ✓ Extruded profiles.
- ✓ Rectangular side rails.
- ✓ The side structure is individually reinforced at each one of the rungs.
- ✓ This series seeks to take up as little space as possible.

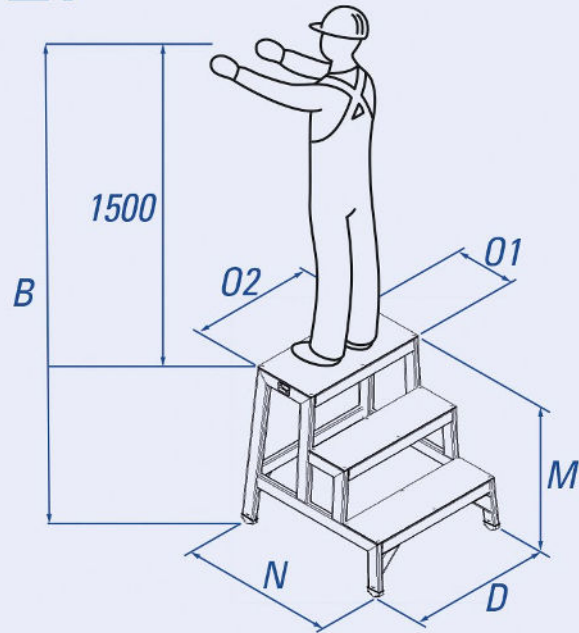

LIGHTWEIGHT ALUMINIUM STEP 51°

Model	Rungs	Weight	Width (D)	Opening (N)	Working Height (B)	Total Height (M)	Platform (O1/O2)
1100201	1	3,5	0,62	0,33	1,75	0,25	0,30 x 0,60
1100202	2	6,6	0,65	0,55	2,00	0,50	0,30 x 0,60
1100203	3	9,9	0,67	0,77	2,25	0,75	0,30 x 0,60
1100204	4	13,4	0,70	0,99	2,50	1,00	0,30 x 0,60

SIZES EXPRESSED IN METERS

STANDARD SIZES (mm) / Lightweight 51° Step depth: 200 (the last 300) Separation between steps: 250